

# Dosing technology

## Dosing system



**preeflow®** **eco-PEN600**  
EP No. 07 113 870.5  
by ViscoTec

### DESCRIPTION

The new and innovative precision volume dosimeter **eco-PEN600** made by ViscoTec offers a wide range of applications for low to medium-viscosity dispensing.

### THEORY OF FUNCTION

**preeflow® eco-PEN** is a rotating and perfectly pressure-tight displacement system. Self-sealing rotor/stator design. Conveyance action by medium displacement in the stator through controlled rotor rotation. Safe conveyance without any modification of the medium. With its suck back option, **preeflow®** ensures clean and controlled material or medium cut-off while preventing post-dripping effects.

### APPLICATION

**On-the-dot dosage** with maximum volumetric precision – **dot-and-bead application** with application speeds adaptable to track speeds – **joint sealing technology**.

### RANGE OF USES

- Fats
- Colours
- Sealing compounds
- Adhesives
- Oils
- Silicones
- Abrasive media

### TECHNICAL FEATURES

- Genuine volumetric dosing
- Viscosity-independent dosing
- Primary pressure-autonomous dosing
- Pressure-tight without valve
- Suck back effect
- Easy to clean
- Controllable dosing flow
- Range of dosing pressures 16 - 20 bar

Self-levelling fluid,  
low-viscosity medium

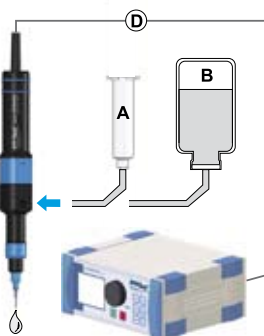

Non-self levelling fluids, medium to high-viscosity medium

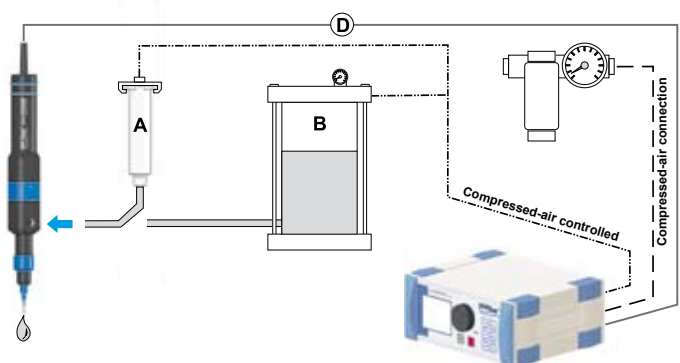

# preeflow<sup>®</sup> eco-PEN600

EP No. 07 113 870.5

by ViscoTec

Fig.: Side view

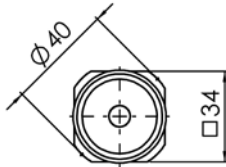
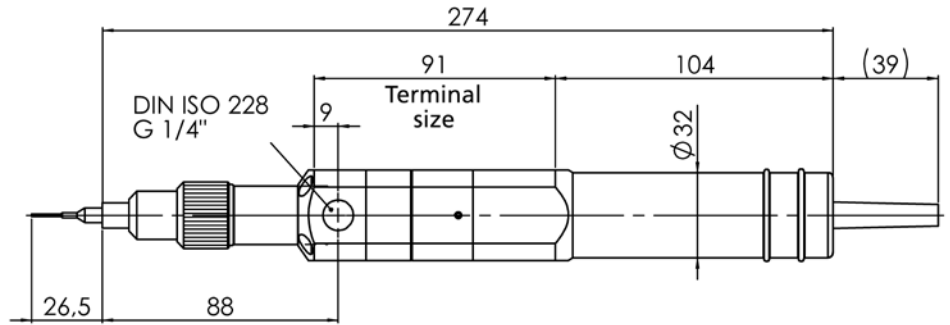
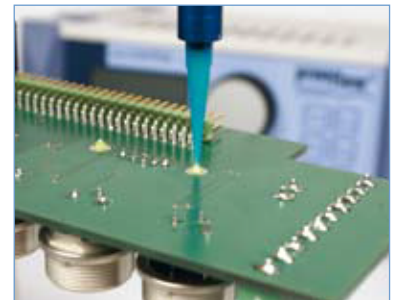

Fig.: Front view



## TECHNICAL DATA

Dimensions:	Length 274mm, □ 34x34mm, ø 40mm
Weight:	approx. 750 Grams
Material infeed:	1/4" cylindrical Whitworth pipe thread DIN/ISO 228
Material outfeed:	Luer lock with O ring, patented
Min. operating pressure:	0 bar, self-levelling-fluid
Max. operating pressure:	0 – 6 bar input pressure, self-levelling-fluid
Max. dosing pressure:	16 – 20 bar
Intrinsic tightness <sup>(1)</sup> :	approx. 2 bar (reference medium approx. 10mPas at 20°C)
Parts in contact with the media:	HD-POM / stainless steel
Seals:	High-molecular PE, VisChem
Static seals:	Viton O ring (medium) NBR (dust)
Motor:	18 – 24 V DC, incremental encoder, planetary gears
Operating conditions:	+10°C – +40°C, air pressure 1 bar
Medium temperature:	+10°C – +40°C
Storage environment:	Dry & dust-free, -10°C – +40°C
Approx. dosing volume per revolution:	0.14 Millilitres per revolution
Accuracy of dosing <sup>(2)</sup> :	± 1%
Repeat accuracy:	> 99%
Min. dosing quantity:	0.015 Millilitres
Volume flow <sup>(3)</sup> :	1.4 – 16.0 Millilitres per Minute



<sup>(1)</sup>Max. dosing pressure and intrinsic tightness will decrease in direct proportion to a decrease in viscosity and increase in direct proportion to an increase in viscosity. Consultation with the manufacturer recommended.

<sup>(2)</sup>Volumetric dosing as absolute deviation in relation to one dispenser revolution. Depends on the viscosity of the dosing medium.

<sup>(3)</sup>Volume flow depends on viscosity and primary pressure.



ViscoTec Pumpen- und Dosiertechnik GmbH  
Geschäftsfeld Komponenten & Geräte

Amperstraße 4 – D-84513 Töging a. Inn  
Tel.: +49 (0) 8631 – 393-400  
Fax: +49 (0) 8631 – 393-500  
info@viscotec.de  
www.viscotec.de



info@preeflow.com  
www.preeflow.com

Virtueller eco-PEN  
www.preeflow.com/service